

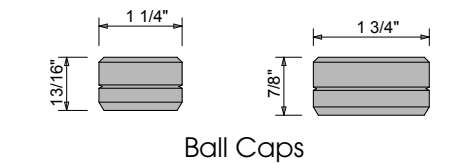

# FURNITURE FEET

Utilizing our collection of seventeen beautifully proportioned vanity feet, and eight unique top caps, Palmer is able to custom fabricate exceptional furniture feet sized to meet your specific needs in a wide range of finishes and sizes.

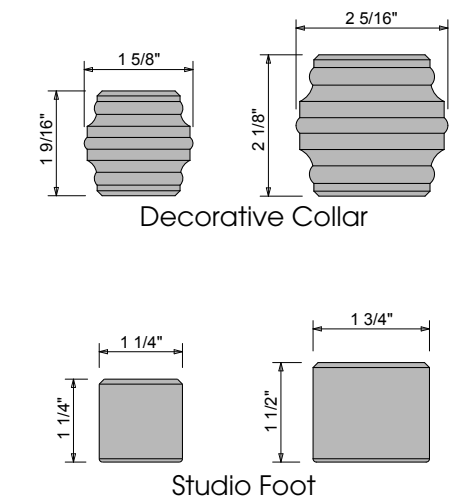
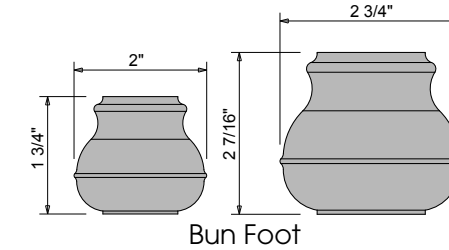
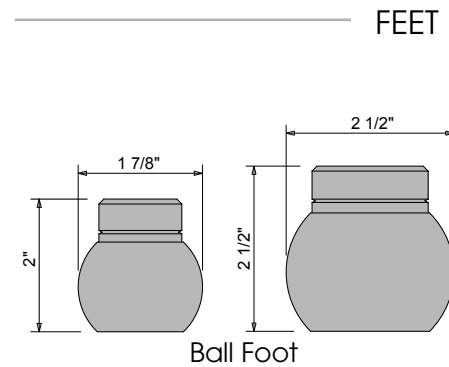
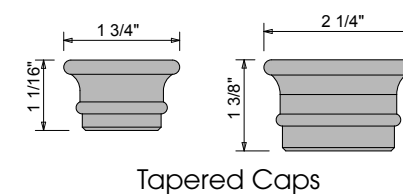
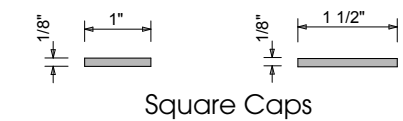
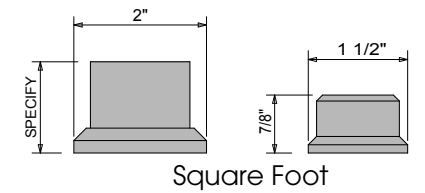
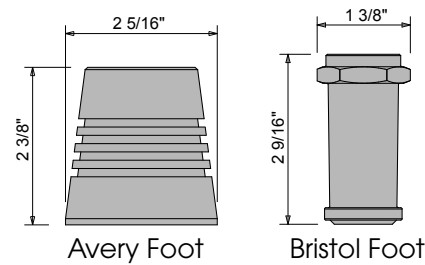
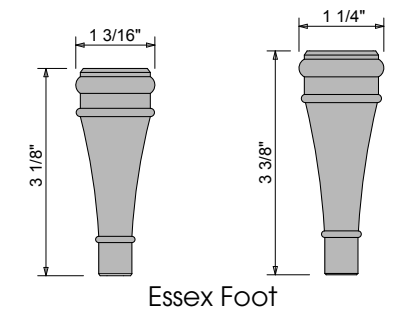
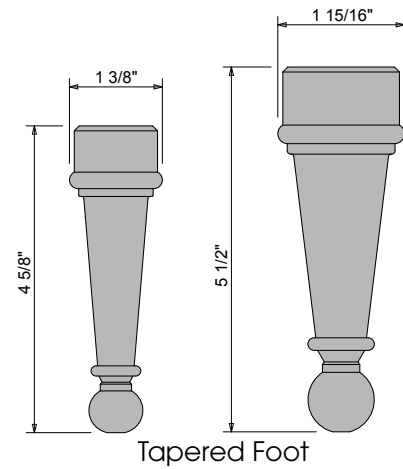

## FEET

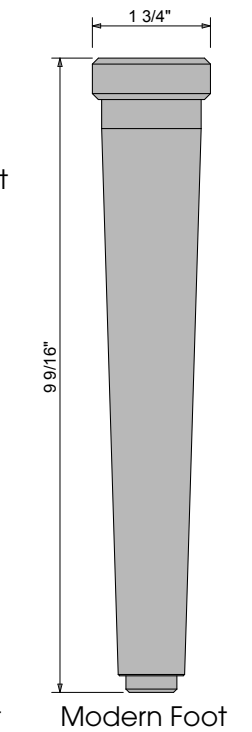
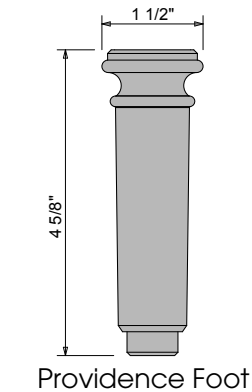
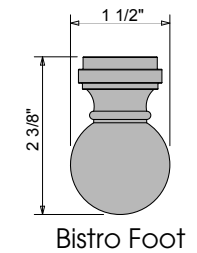
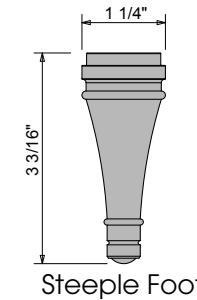
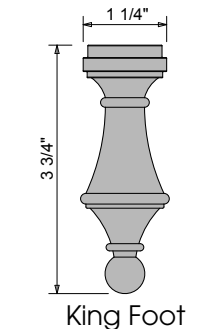

All feet can be fitted with a Screw Plate or a Threaded Stud

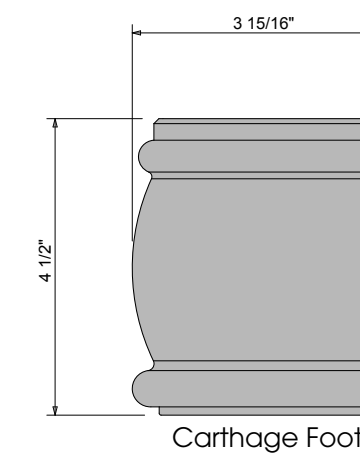
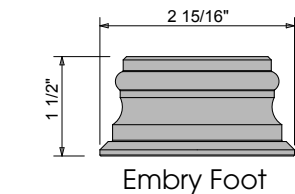

## TOP CAPS

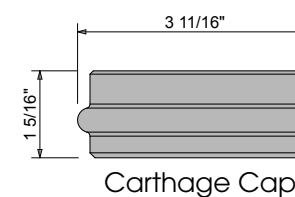
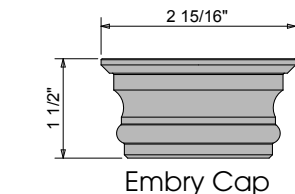
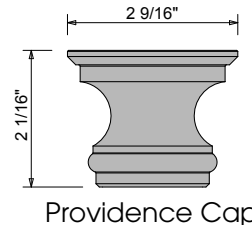
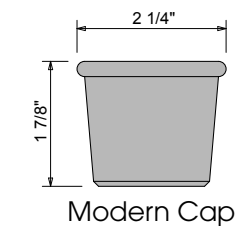

American Manufacturing



Providence, Rhode Island