

# SHELVING SYSTEM ASSEMBLY INSTRUCTIONS

**RACK** | **CANTILEVER**  
S H E L V I N G

PALMER INDUSTRIES  
**EDGE** SHELVING  
S Y S T E M S

## MOUNTING TO WALL ONLY

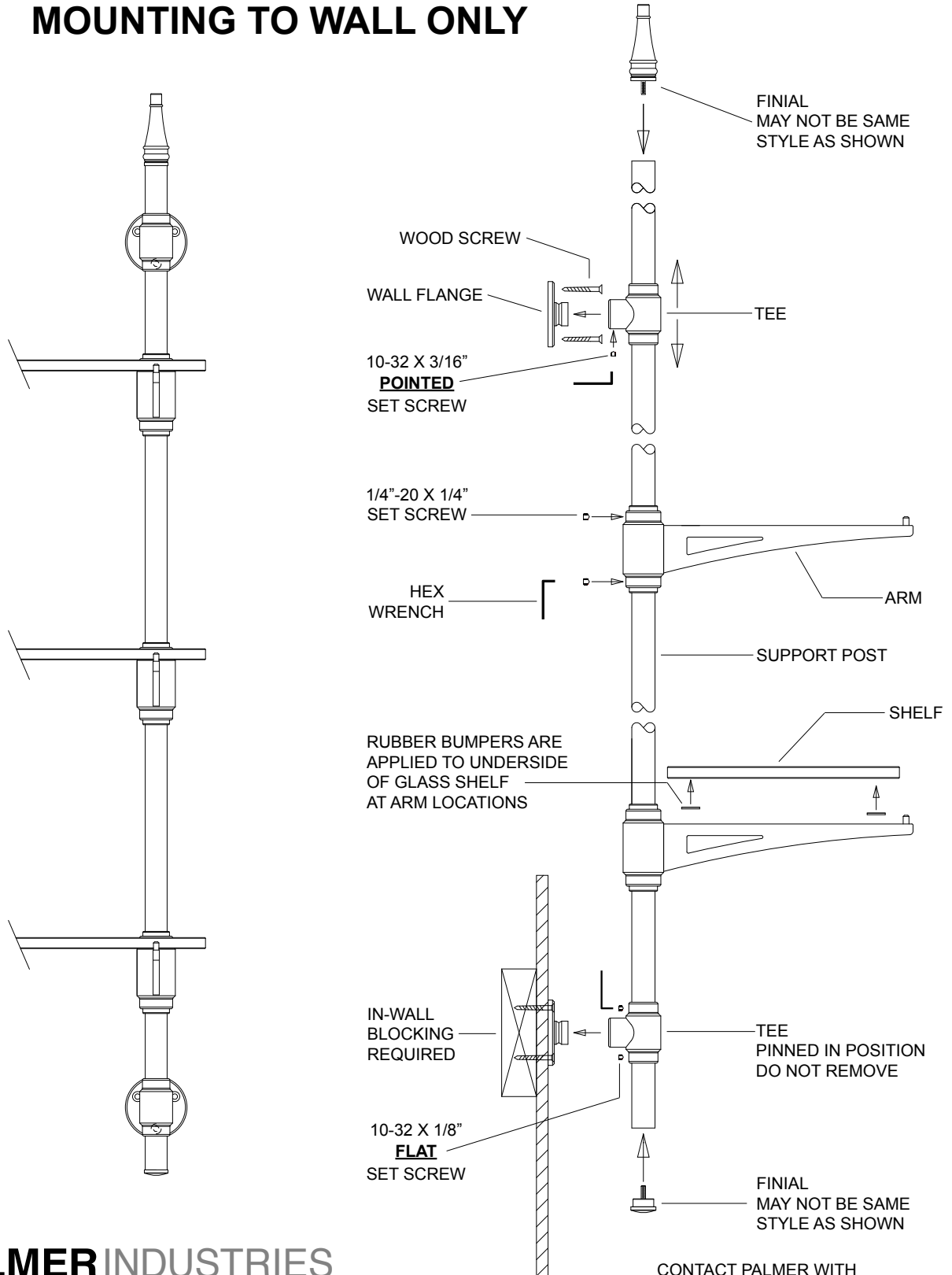

**PALMER INDUSTRIES**  
CUSTOM ARCHITECTURAL METALWORK

CONTACT PALMER WITH  
ANY INSTALLATION QUESTIONS  
401-421-1730

rev: 052020

# SHELVING SYSTEM ASSEMBLY INSTRUCTIONS

# RACK | CANTILEVER S H E L V I N G

# PALMER INDUSTRIES EDGE SHELVING SYSTEMS

## MOUNTING TO WALL ONLY

CAREFULLY UNPACK AND INSPECT YOUR PALMER PRODUCT.

THE SHELVING UNIT SHOULD BE CAREFULLY ASSEMBLED ON A CLEAN AND PADDED SURFACE TO AVOID ANY SCRATCHING OR DAMAGE. FOR UN-LACQUERED BRASS FINISHES, PLEASE WEAR CLEAN GLOVES TO PREVENT FINGERPRINTS.

- 1 THE BOTTOM WALL MOUNT TEE IS PERMANENTLY PINNED INTO POSITION - DO NOT REMOVE. ALL COMPONENTS MUST BE SLID DOWN OVER THE TUBE FROM THE TOP. PLEASE BE VERY CAREFUL NOT TO SCRATCH THE TUBE WHEN ASSEMBLING THE COMPONENTS. PAY PARTICULAR ATTENTION THAT NO SET SCREWS PROTRUDE INSIDE THE FITTING TO AVOID SCRATCHES.
- 2 ASSEMBLE THE COMPONENTS ONTO THE SUPPORT POSTS AND SPACE ACCORDING TO THE CUSTOMER DRAWING. POSITION THE WALL FLANGES SO THAT THEY ARE IN ALIGNMENT WITH THE SOLID WOOD BLOCKING. MAKE SURE THE COMPONENTS ARE BURR FREE AND THE SET SCREWS (IF INSTALLED) ARE BACKED OUT FAR ENOUGH TO AVOID SCRATCHING THE POSTS.  
  
TIGHTEN THE SET SCREWS ONLY ENOUGH TO KEEP THE COMPONENTS FROM SLIDING - FINAL TIGHTENING AND ADJUSTING WILL BE DONE AFTER THE FLANGES HAVE BEEN SECURED TO THE WALL.
- 3 CAREFULLY PLACE THE POST ASSEMBLIES INTO POSITION ON THE WALL, AND MARK THE NECESSARY SCREW LOCATIONS. DRILL APPROPRIATE PILOT HOLES FOR THE SCREWS.
- 4 SEPARATE THE WALL FLANGES FROM THE TEES BY LOOSENING THE 10-32 X 3/16" POINTED SET SCREWS. SECURE THE WALL FLANGES TO THE WOOD BLOCKING IN THE WALL WITH THREE PROVIDED WOOD SCREWS EACH.

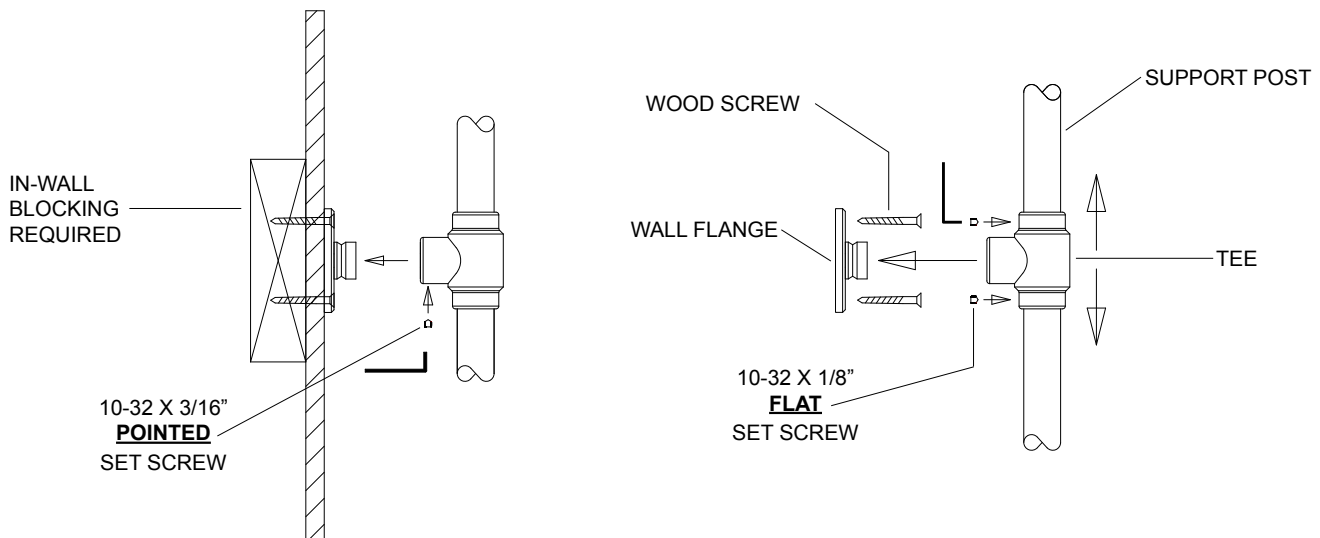

- 5 SECURE THE SUPPORT POSTS TO THE WALL FLANGES. THE UPPER TEE MAY BE ADJUSTED SLIGHTLY TO HELP LOCATE ONTO THE WALL FLANGES. IT IS IMPORTANT THAT THE TEES ARE SECURED TO THE WALL FLANGES USING THE PROVIDED 3/16" **POINTED** SET SCREWS.

WHEN ALL FLANGE COMPONENTS ARE PROPERLY ALIGNED, TIGHTEN SET SCREWS SECURELY.

- 6 CORRECTLY POSITION ARMS AND TIGHTEN 1/4"-20 SET SCREWS SECURELY.